

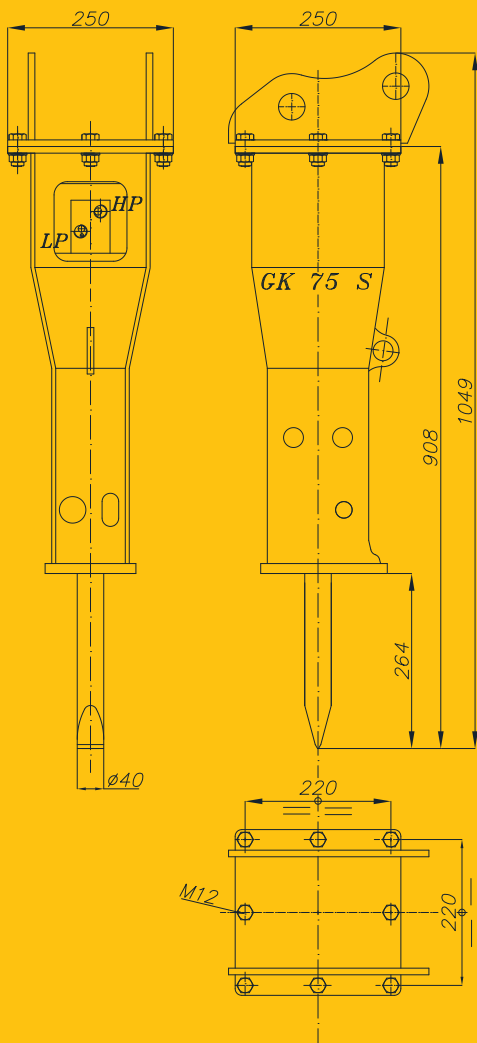

Italdem®



GK 75 S-NG HYDRAULIC BREAKER

OPERATING WEIGHT	75 KG (165 LB)
TOOL DIAMETER	40 MM (1.57 IN)
OIL FLOW	13÷25 L/MIN
WORKING PRESSURE	95÷105 BAR (1378÷1523 PSI)
RELIEF VALVE	140 BAR (2030 PSI)
MAX. BACKPRESSURE	12 BAR (174 PSI)
BLOW ENERGY	160 JOULE
REQUIRED POWER	4.4 KW (6 HP)
IMPACT RATE	750÷1430
CARRIER WEIGHT	0.5÷2 T (1102÷4409 LB)
MAX. NOISE LEVEL (SILENCED VERSION)	93 DB-A
INNER DIAMETER HP LINE	16 MM (0.63 IN)
INNER DIAMETER LP LINE	20 MM (0.79 IN)